

# Seeded Hydrogen in Nuclear Thermal Propulsion (NTP) Engines

*Dennis Nikitaev - Mechanical and Aerospace Engineering*

## Overview

Seeding hydrogen is the process of adding a heavy noble gas such as Argon, Krypton, or Xenon to the hydrogen propellant. This is done to reduce pressure losses, improve conductive heat transfer, and densify the propellant at the expense of specific impulse and vehicle mass.

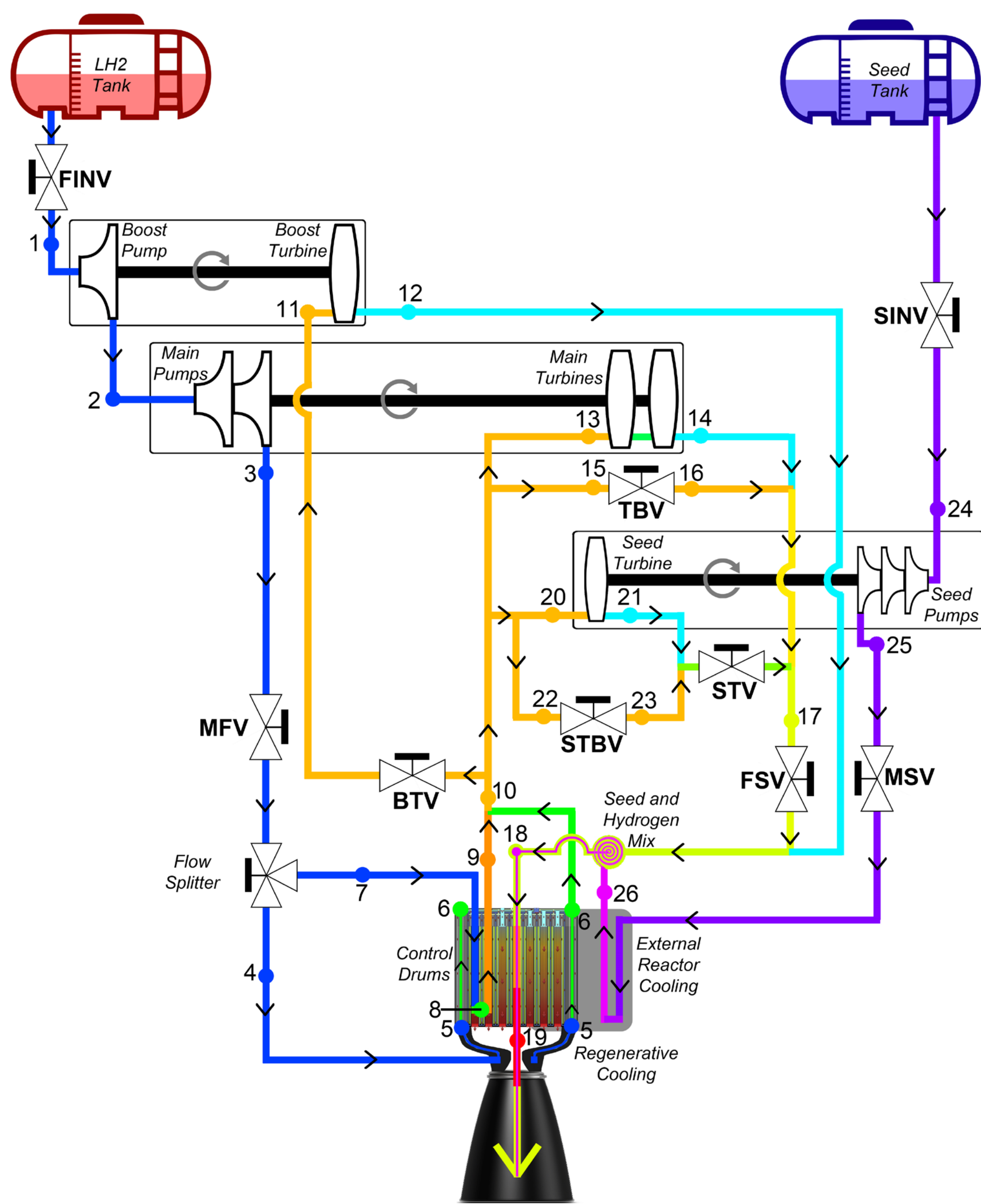

## Methodology

A MATLAB Simulink model of the DRA 5 Aerojet Rocketdyne (AR) NTP engine was constructed and verified. Each block inside the model incorporated its own codes with a 1mm resolution. This model was then modified to incorporate extra turbomachinery and ducting to allow for the capability of seeding hydrogen. The base line vehicle was AR's Mars Architecture DRA 6.

## Acknowledgements

Acknowledgements:  
Mentor/Advisor: Dr. L. D. Thomas  
Funding provided by NASA NTP Program Office

## Results

For the same vehicle volume:

- Increased  $\Delta V$
- Decreased reactor power
- Increased thrust or decreased strain on turbomachinery
- Increased chamber temperature
- Decreased specific impulse
- Increased mass

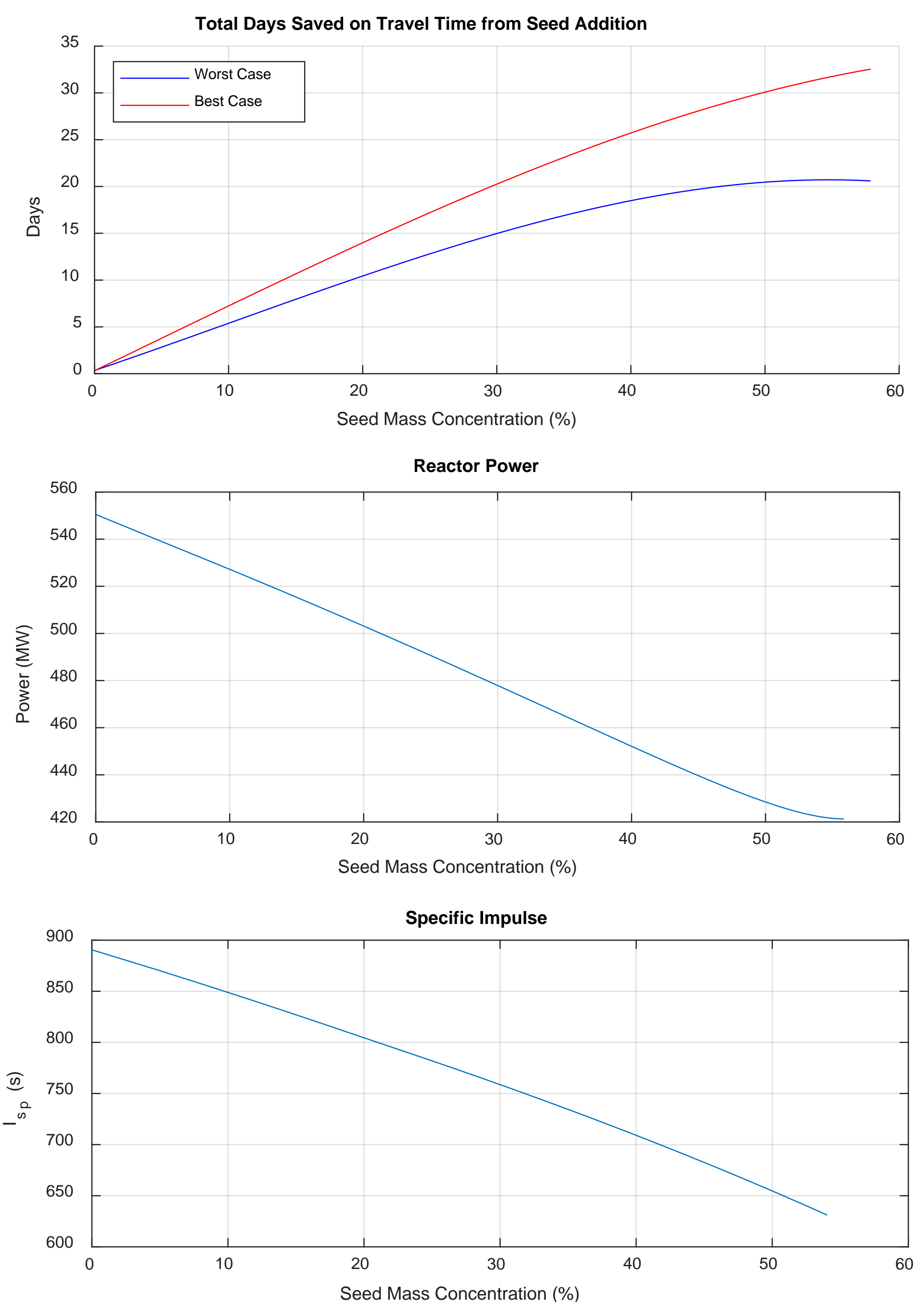

## Impact

Seeded hydrogen propellant will allow either faster or further travel throughout the solar system with a vehicle of the same size. The option to decrease reactor size is also available due to decreased reactor power. Internal pressure losses are also less thus resulting in either higher thrust or less powerful turbomachinery.